

The Confusion Surrounding “Stray Voltage”

Jim Burke, InfraSource Inc., Fellow, IEEE

Abstract – While “stray voltage” has been a concern for farm livestock for many years, it is only within the past few years that the term has been associated with human fatalities. The industry has seen an expansion of the term’s usage to describe events that some engineers feel is incorrect. This situation has resulted in costs to utilities exceeding many millions of dollars that has a questionable impact on customers increased safety.

The purpose of this paper is to discuss the confusion that now exists in the area of “stray voltage”. The paper will discuss the traditional definition of the term “stray voltage”, as well as the recent usage of the phrase to describe more dangerous conditions such as step-and-touch voltages, temporary overvoltages, contact voltages, etc. Finally, the paper will address the status of the industries response to this issue. It will discuss the measures taken by some utilities as well as the IEEE to establish some sort of industry guidelines to address these issues.

Index Terms – distribution, grounding, stray voltage, stray current, safety, farms

I. Introduction

For most of my career, spanning over 40 years, the term “stray voltage” has meant one thing, i.e. the voltage between the neutral conductor and the earth, resulting from unbalanced current. Since unbalanced current is an integral part of a 4 wire multi-grounded system, it was considered normal. The only issues that arose were from the dairy industry and occasionally from a pool owner. **Stray Voltage was not considered dangerous**, especially to humans, so the interest level in the industry was relatively low.

Contrast this with today’s perception (a perception I might add resulting from the legal environment, and non technically orientated people), where stray voltage has been blamed for every type of electrical phenomena, the most

newsworthy, of course, those associated with death. A true mess!

What we have historically called “stray voltage” refers to voltages that are generally less than 5 volts and rarely above 10 volts. These voltages are significantly less than voltages considered dangerous by OSHA, NESC and NEC who set the limit at 50 volts and amateur radio operators (ARRL) who set the limit at 35 volts.

Stray voltage is not the voltage associated with “step-and- touch”, high impedance faults, temporary overvoltages, static discharge, contact voltages, etc. And finally, although everyone knows that current kills...not voltage, “stray current” and “stray voltage” are not directly related.....at all.

II. Terminology Issues in 2006

The term “stray voltage” is taking on a life of its own and becoming all things to all people. The following are terms interchanged with the term “stray voltage” which are incorrect (to those of us in the industry for a while) and causing a lot of the present confusion:

a. **Stray Voltage** – the term as generally defined by utility engineers refers to the voltage imposed on the distribution primary neutral due in large part to return currents (unbalanced loads). In the context of the last 40 years, the voltage is associated with problems in dairy farms and generally the voltages do not exceed about 10 volts. It is not considered lethal.

b. **TOV** – Temporary Overvoltages (TOV) are commonly referred to as stray voltages which they are not. TOV’s are 60 Hz overvoltages that occur on the unfaulted phases of a 4-wire multi-grounded system during a fault. They are voltages primary associated with the rating of arresters for lightning protection. Their duration is very short and a function of the overcurrent protection speed being used on the distribution system.

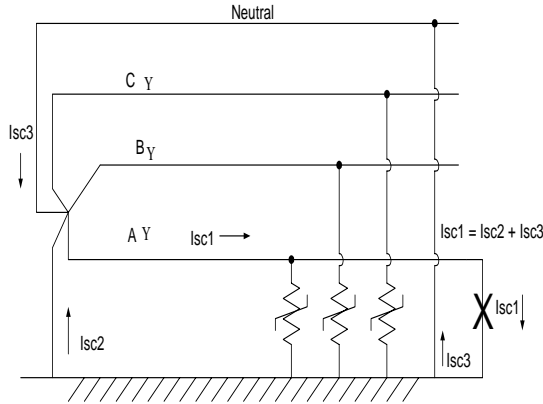

Figure #1 – TOV Resulting from line to ground fault

c. **Contact Voltage** – We normally use the term contact voltage to address the condition where the “hot” lead (120 volts or more) contacts the outside shell of something like a streetlight. This voltage is dangerous and can result in death. Contact voltage is not “stray voltage” although it is sometimes misapplied in this context.



Figure #2 – Live wire resulting in possible contact voltage

d. **Step and Touch Voltages** – “Step and Touch” voltages are generally associated with the high voltages that can occur between the two feet of an individual or a hand and foot, during fault conditions. They are normally a concern in substations, where currents can be very high (>10,000 amperes) and where close proximity of personnel creates safety concerns. In short, “step and touch” voltages have always been associated with safety because they can be very dangerous.

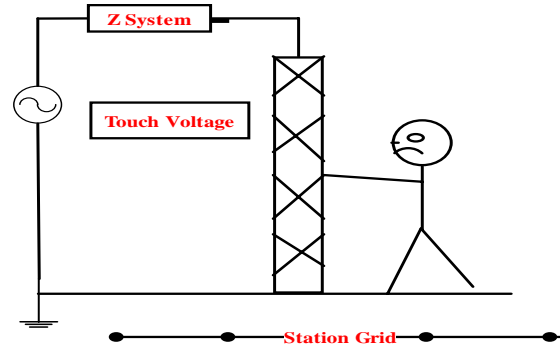

Figure #3 – Step-and-Touch Voltage in Substation

e. **Static Discharge** - Somehow the concept of “static electricity” has been adopted by some as another type of stray voltage. It is not. Static electricity, as most of us see it, is usually produced by friction i.e. when two materials are rubbed together. Static electricity in the atmosphere produces lightning.

f. **High Impedance Faults** – High impedance faults occur when a phase conductor falls on the ground. The contact impedance between the earth and the conductor is very high (>100 ohms) and consequently very low values of fault current (generally less than 40 amperes) result making overcurrent protection virtually impossible. High impedance faults are very dangerous because they create very **high “step and touch” voltages**, which will usually result in death at distribution primary voltage levels. High impedance faults are extremely dangerous even at the lower voltage levels like 120 volts.

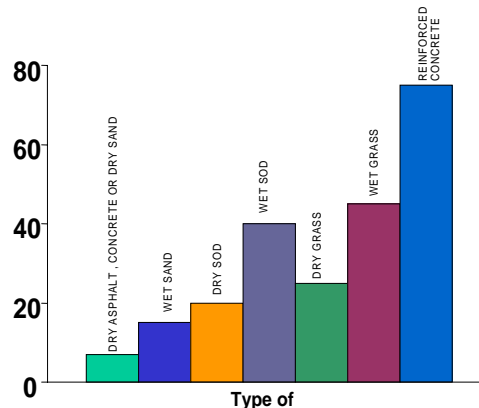

Figure #4 - Plot of current magnitude (in amps) for faults on different types of surfaces

f. Stray Current – I’ve heard the term “Stray Current” in recent years and really do not know what it is. It would appear that some of those using this term are saying that any current entering the earth is really a stray current, the implication being that it wasn’t supposed to go there. Such nonsense!! The earth has always been considered a path for electrical currents by utility, radio and industrial engineers (using the same logic, we should call radio waves going through the air, “stray radio waves”). Some currents are supposed to go to the earth...that’s why we use grounds...or so I thought.

There are those who suggest that we monitor “stray current”, not “stray voltage”, since current causes death...not voltage. We all know that it is current through the human body that can cause death...never heard anyone deny this. I would suggest, however, that the only way to get current through your body is to have a voltage difference. The more voltage, the more current. On the other hand (no pun intended), you can have very high currents in the earth in places like substations, during fault conditions that are safe. This is because the ground mat of the substation creates a semi-equipotential plane that insures that the voltages across your body are low enough to not result in injury (i.e. lots of current but not lots of voltage). I would suggest that concentrating on monitoring “stray current” is a waste of time.

Finally, the path of unbalance current flow on a distribution system is very complex and virtually impossible to analyze accurately. One thing that greatly complicates an accurate model is that the loads are distributed making the flow of current between the neutral and earth very complex.

Figure #5 shows the percentage of current in the neutral for various sizes of wire. The fault, in this case, is located 10 miles from the substation and as we can see, most of the current at the fault location (could be load as well) is in the neutral. Near the middle of the feeder there is very little exchange of current, which means that in this area the stray voltage problem should be less. However, we start to see a shift in current near the substation which indicates higher stray voltages in the vicinity of the substation.

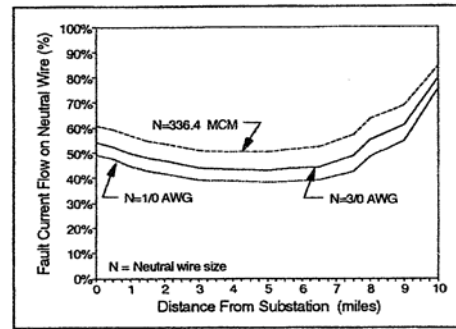

Figure #5 – Division of Current for Various Neutral Conductor Sizes

III. Characteristics of Stray Voltage

a. **Utility Contribution** - When current flows through the neutral of a primary distribution system, it creates voltage. This voltage, generally a volt or two, is transferred by the distribution transformer to the customer. Figure #6, shows a distribution transformer where the primary and secondary neutrals are not connected. If this were the normally the case, the utility would not see the majority of stray voltage complaints. However, the Code requires that the 2 neutrals be connected. This means that the small voltage (e.g. 5 volts) on the primary neutral is now imposed on the secondary. Now there can be a neutral-to-earth voltage which is caused by the utility system (it should be noted that the customer can and does cause many of the stray voltage problems).

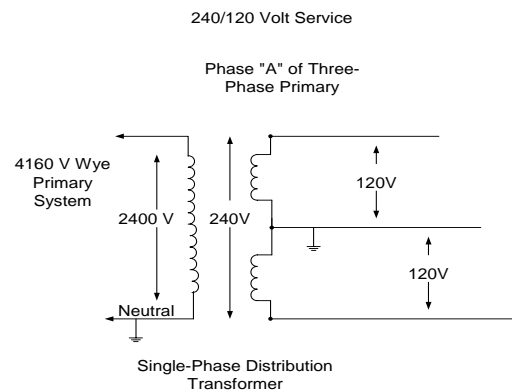

Figure #6 – Distribution transformer without neutral interconnection

b. **Utility Mitigation Issues** - Stray Voltage issues are difficult. This is due to the fact that the cause(s) of the problem are complex and mitigation techniques may not be effective. An example of the difficulty is shown in Figure #7. It would normally be assumed that better grounding reduces the level of stray voltage. This being the case, if the substation grounding is improved, one would conclude that stray voltages are reduced. Such is not necessarily the case as is shown in figure #7. Voltages at the substation are reduced but those out on the feeder actually increase due to the increase in neutral current. A similar phenomena occurs when ground rods are driven at a customer location, i.e. the voltage at the ground rod location may go slightly down but stray voltages in other areas could go up.

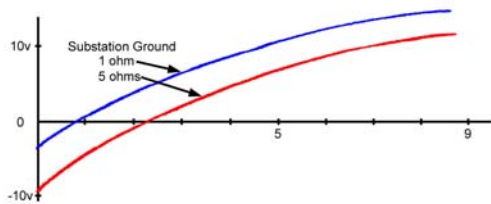

Figure #7 – Effect of Substation Grounding on Stray Voltage

Utilities use a number of methods (see figure #8) to reduce stray voltage, including better grounding, larger neutrals, balancing, etc. While many of these methods may help, they may not be sufficient to satisfy the requirements of some state commissions. Probably the most effective tool is a neutral isolator, which isolates the neutral during normal conditions.

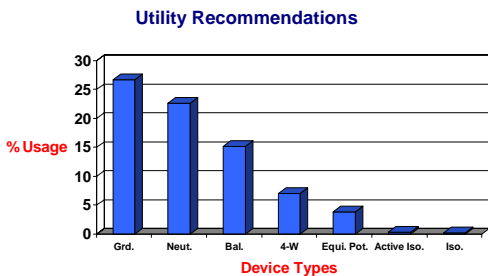

Figure #8 – Stray Voltage mitigating methods used by utilities

c. Farm Considerations

The farm industry has been interested in the subject of stray voltage for many years due to the concern with the impact of this voltage on the health and production of their dairy herds. Figure #9, shown below, illustrates the impact of

various levels of stray voltage on cows. As can be seen it takes about 5 volts to cause moderate activity. It should also be noted that some studies performed by reputable universities suggest that the effect of stray voltage on the health of cows has been greatly exaggerated.

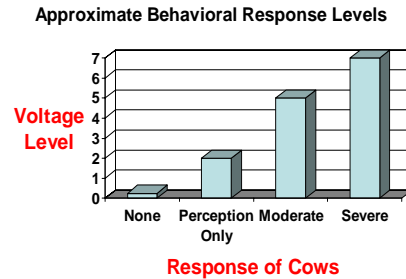

Figure #9 – Response of cows to stray voltage

The mitigation techniques used by farmers is shown in figure #10. As can be seen the primary device used is apparently an equipotential plane which allows the area in the vicinity of the cow to be at the same potential.

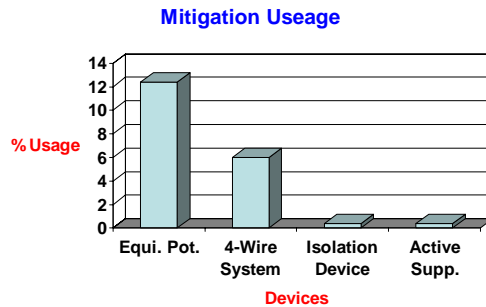

Figure #10 – Stray voltage mitigation used by farmers

d. Human Safety

Very low levels of current can result in death. As shown in the table below, it only takes about 0.1 amps to cause a human body to go into ventricular fibrillation. The resistance of the human body is normally assumed to be about 500 ohms (my tests show values much higher than this). A stray voltage of 5 volts, which is a reasonably high value, would consequently result in a level of current (0.01 amperes) far below that necessary to cause death. This being the case, it does not make sense to associate the possibility of death with the term “stray voltage”. This is in direct contrast to voltages caused by high impedance faults, substation step and touch voltages, contact voltages, etc. The term “stray

voltage”, as it has historically been used, was not considered to be dangerous.....as is implied by the media today.

Dangerous voltages must be mitigated immediately to reduce the possibility of human fatalities. Stray voltages, on the other hand, are very difficult to diagnose and can be extremely difficult to mitigate, sometimes taking many months to resolve. For this reason, it doesn't make sense to treat them in the same manner as other more serious voltage concerns.

Effect of Electric Shock

6 Amps or More	Sustaining myocardial contraction followed by normal rhythm
0.1 to 2-3 Amps	Ventricular fibrillation
50 Milliampere	Pain, fainting, exhaustion, mechanical injury
16 Milliampere	"Let go current"
1 Milliampere	Threshold of perception

VII. Conclusions

The subject of “stray voltage”, once only mentioned in relation to dairy farms, has become an issue in the industry for other reasons, not the least of which is safety. The general reduction of industry participation in the standards writing function of IEEE has created a situation where non professionals, such as state legislators and lawyers are rewriting definitions, creating new terms and creating arbitrary limits and testing procedures costing the industry many millions of dollars which could have been used far more wisely to promote both safety and reliability.

Jim Burke is a Fellow of the IEEE, and an Executive Advisor with InfraSource Inc. in Raleigh, North Carolina. He was the chair of the IEEE Working Group on Distribution Neutral Grounding which developed the present guide in 1991. He is a member of the IEEE Working Group on Stray Voltage.

james.burke@infrasourceinc.com
distjimb@aol.com